

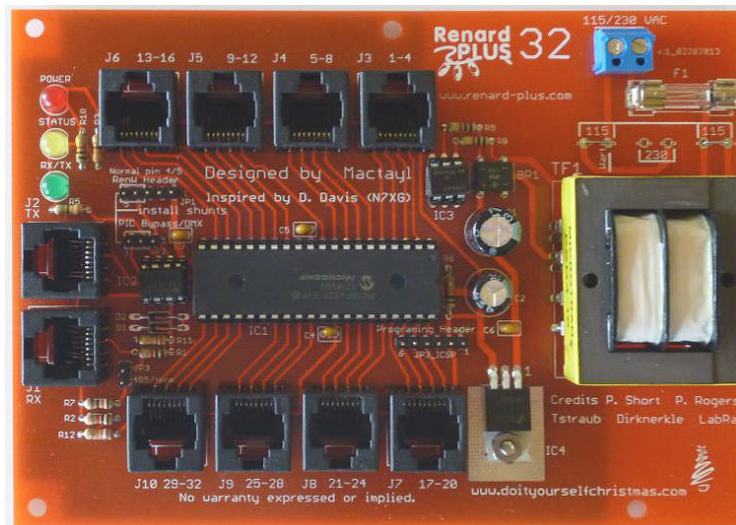

RP32 - 32 Channel Controller



Sep 2014

Version 1.00 / 1.01* Board

Document Revision 1.10

*1.00 and 1.01 are electrically identical just silkscreen changes

Table of Contents

TABLE OF CONTENTS	2
1. INTRODUCTION TO RENARD	3
2. OVERVIEW OF RENARD PLUS 32	4
3. ASSEMBLY INSTRUCTIONS	5
3.1 RENARD PLUS 32 BOM	5
3.1.1 Transformer Options	6
3.1.2 External power supply	6
3.2 PARTS ASSEMBLY.....	7
3.2.1 First Things First.....	7
3.3 RENARD PLUS 32 ASSEMBLY GUIDE.....	8
3.3.1 Set Voltage Option	8
3.3.2 Install the resistors	9
3.3.3 Install the diodes	10
3.3.4 Install IC sockets and Bridge Rectifier	11
3.3.5 Install the capacitors.....	12
3.3.6 Install the light emitting diodes	13
3.3.7 Install Misc. Parts	14
3.3.8 Initial Testing / Final Assembly.....	17
3.3.9 Install the ICs:.....	18
3.3.10 Picture of completed board	18
4. FINAL STEPS	19
4.1 PROGRAMMING THE PIC	19
4.2 JUMPER SETTINGS / HEADERS.....	19
4.2.1 JP1 XBee Header.....	19
4.2.2 JP2 PIC Bypass / DMX	19
4.2.3 JP3 RS485 Terminator.....	20
4.2.4 Programming (ICSP Header)	20
4.3 CONNECTING THE RENARD TO YOUR PC.....	21
4.3.1 RJ45 Wiring.....	21
4.3.2 Computer Setup	21
4.4 FINAL TESTING	22
4.4.1 Diagnostic LED Status Lights.....	22
5. PARTS PLACEMENT DIAGRAM	23
6. NOTES	24

Renard-Plus, Salem, Oregon 97302
 © 2011-2013 Renard Plus. All rights reserved.
 Published 2013
 Printed in United States

Renard-Plus (“Developer”) has made every effort to ensure the accuracy of this document. Developer makes no warranties with respect to this documentation and disclaims any implied warranties of merchantability and fitness for a particular purpose. The information in this document is subject to change without notice. Developer assumes no responsibility for any errors that may appear in this document.

The information contained herein is the exclusive and confidential property of Renard Plus, except as otherwise indicated.

We wish to also thank the Do It Yourself Community for the inspiration it has given us in the development of this product.

Trademarks the Renard Plus logo are trademarks of Renard Plus.

All other trademarks acknowledged.

1. Introduction to Renard

Renard is the name of a “do-it-yourself” (DIY), computer-controlled, PIC-based dimmer light control concept. It also refers to a family of dimming controllers that have been designed and built based on this concept.

The Renard design concept was originally described by Phil Short in the [Simple PIC-Based 8-Port Dimmer](http://computerchristmas.com) 'How-To' on the <http://computerchristmas.com> website. Since then there have been many enhancements and new designs based on this hardware. There have been many contributors to advancing Renard technology including M. Macmillan, D. Davis, P. Rogers, T. Straub, D. Haberle, A. Williams and others.

Renard controllers typically rely on a separate computer running a light sequencing program to send it real-time sequences of controller commands to sequence the lights. The computer communicates with the Renard via RS232, RS485, or wireless (depending on the design) and the Renard controls the lights either through built-in power control (power is output directly to the lights), or via separate “SSRs” (solid state relays supply the power when commanded by the controller).

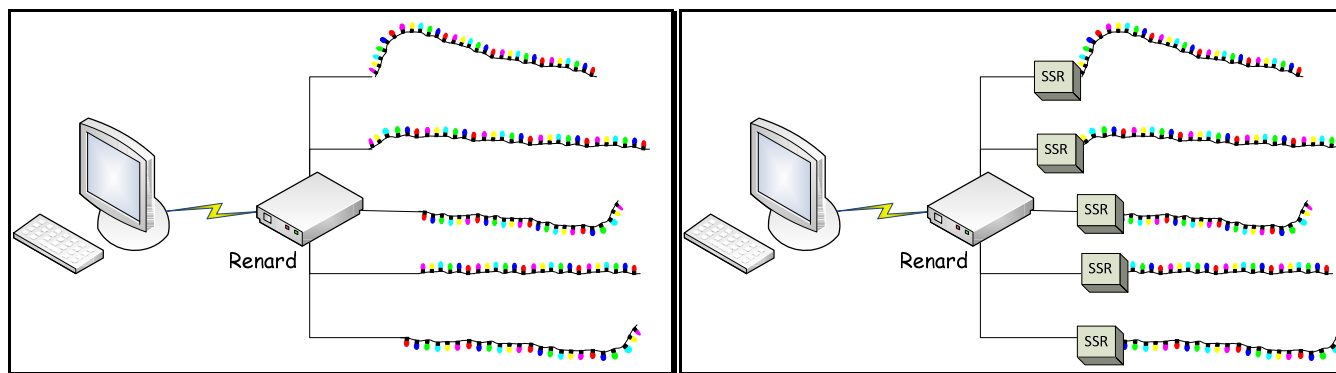

Example Renard configurations

Output of the Renard can be either control signals (to an SSR), direct AC line voltage (110, 100/220, or 220), or DC voltage depending on the design.

Renard is a DIY hobbyist effort and there is a vast amount of products and related peripherals to select from including the Renard Plus 32 Controller. To obtain a specific design, there might be “buy a parts kit and/or blank PCB” offering at a site (such as from www.renard-plus.com), “etch it yourself” files for true DIY, or coop/group buys for kits and PCBs also in forums (like DIYChristmas.org).

2. Overview of Renard Plus 32

This guide covers the Renard Plus 32. This board is designed to take “Renard” serial communications via RS485 from a control computer, and output full dimming light control on its 8 RJ45 Renard SSR (each capable of driving up to 4 channels). These outputs typically connect to up to 8 solid state relay (SSR) modules each with 4 channels of outputs for a grand total of 32 individual controllable/dimmable channels. The SSR controller can be any of a variety of SSR modules which might control AC (like the DirkCheapSSR) or DC (like the LabRat DCSSR) or a combination thereof. The type of light you want to control will dictate the type of SSR you choose to use.

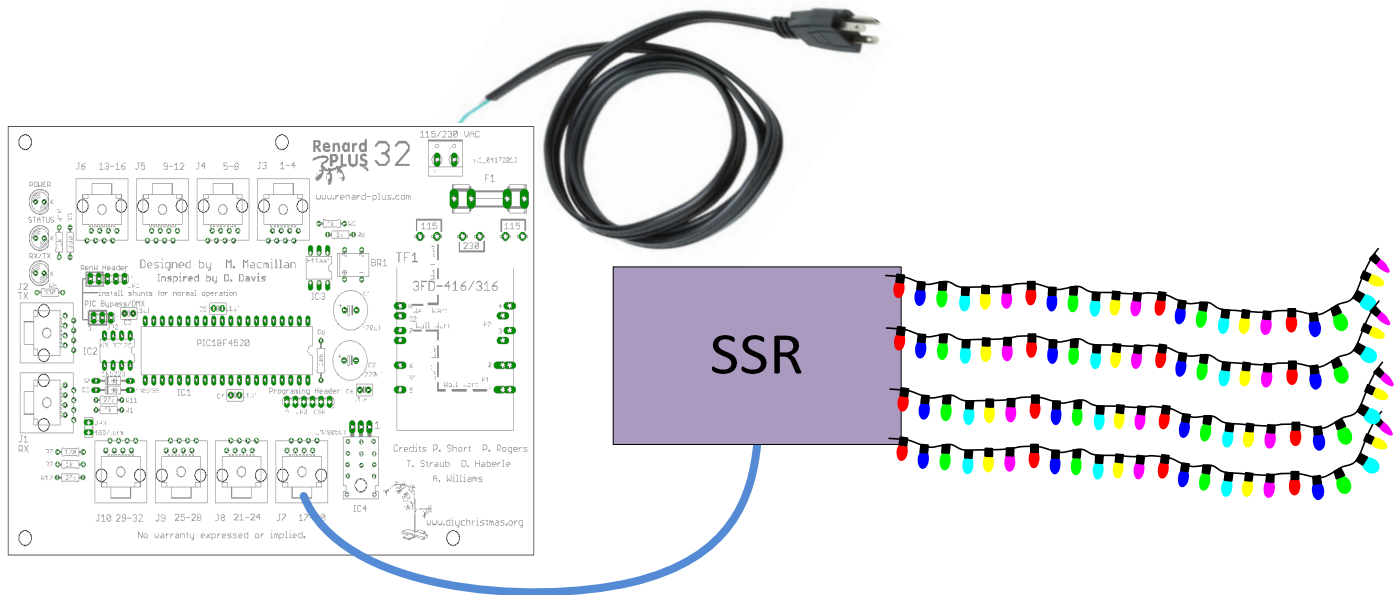

Feature		Detail
	Name	Renard Plus 32
	Target use	AC or DC Light control
	Channel Count	32
	Power input	110v or 220v AC (an AC “wall wart” option is also described in the Transformer section).
	Power output	No – controls external SSR
	Dimmable?	YES – PWM
	Status Indicators?	YES
	Channel Indicators?	NO
	Control Input – Renard	YES – RS485 or optional wireless
	Control Input – DMX	Planned
	Daisy-chain output	YES – Renard RS485 pinout
	Wireless	Option – w/add-on Snap-In board
	On board programming	Yes through ICSP connector



















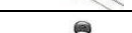
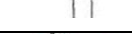

3. Assembly Instructions

This section covers the construction of the Renard Plus 32 controller board. It approaches these tasks as a learning exercise for new builders, so that they can develop proficiency and self-confidence. The project itself is quite simple and if you follow the steps *carefully*, you should have a working controller when you are done. Additional information and guides on techniques and tools can be found in the “Tools and Parts ID Guide” at:

[www.renard-plus.com/files/Tools and Parts ID Guide.pdf](http://www.renard-plus.com/files/Tools_and_Parts_ID_Guide.pdf)

3.1 Renard Plus 32 BOM

The following is the Bill Of Material for building the Renard Plus 32. The link to the Mouser project is: <https://www.mouser.com/ProjectManager/ProjectDetail.aspx?AccessID=7d6712b5a4>

Picture	Designators	Description	Qty	Mouser P/N
	R1, R2, R8, R9, R10	1k ohm resistor 1/4 watt	5	291-1k-RC
	R3, R5	330 ohm resistor 1/4 watt	2	291-330-RC
	R6	10k ohm resistor 1/4 watt	1	291-10k-RC
	R7	120 ohm resistor 1/4 watt	1	291-120-RC
	R11, R12	27k ohm resistor 1/4 watt	2	291-27k-RC
	D1	1N5239 (9.1v) zener diode	1	78-1N5239B
	D2	1N5229 (4.3v) zener diode	1	78-1N5229B
	C1	470uf 25V Electrolytic Cap	1	647-UVZ1E471MPD
	C2	220uf 25V Electrolytic Cap	1	647-UVZ1E221MPD
	C3, C4, C5, C6	.1uf cap	5	81-RDER71H104K0K103B 81-RCER71H104K0A2H3B
	P1	Tyco Terminal Block 2 pin vertical	1	571-7969492
	J1-J10	Modular Jacks 8 PCB TOP ENTRY	10	571-5556416-1
	IC1	IC & Component Sockets 40P	1	517-4840-6000-CP <i>or</i> 649-DILB40P223TLF
	IC2	8 pin IC socket (optional)	1	517-4808-3004-CP
	IC3	6 pin IC Socket (Optional)	1	571-1-390261-1
	ICSP, JP1, JP2, JP3	2.54mm 16 pin male header cut to fit: ICSP, JP1, JP2, JP3	1	571-16404526 (less expensive alternatives exist)
		Shunts for Xbee header & Bypass	3	737-MSC-G
	IC1	PIC Microcontrollers (MCU) PIC18F4520 or 4620 and 4525	1	579-PIC18F4520-I/P
	IC2	65LBC179	1	595-SN65LBC179P
	IC3	H11AA1	1	782-H11AA1
	IC4	LM7805CT voltage regulator	1	512-LM7805CT
	BR1	BR1 4 pin Bridge rectifier 1amp dip	1	625-DF02MA-E3
	Status	yellow 5 MM LED	1	78-TLHY5405

	Power	Red 5 MM LED	1	78-TLHR5401
	RX/TX	Green 5 MM LED	1	78-TLHG5401
	F1	Fuse Clips and Holders PC FUZE CLIP 5 MM	2	576-05200001N
	F1	Fuse Cover (Optional)	2	534-3527C
	F1	Fuse Amp 800mA fast acting (Note order spares "just in case")	1	504-GDB-800MA
	TF1	Transformer pri.115/230volts sec.8volts 800ma. (See below)	1	838-3FD-416

3.1.1 Transformer Options

The Parts list above only calls out one of the many transformers that can be used on this controller board. The following are other transformers that can be used:

	Mouser P/N	Primary Volts (AC)	Sec. Volts (AC)	Current (ma)
Dual Voltage	838-3FD-412	115 / 230	6.3	1000
	838-3FD-416	115 / 230	8.0	800
	838-3FD-420	115 / 230	10.0	600
	838-3FD-424	115 / 230	12.0	500
	838-3FD-312	115 / 230	6.3	400
	838-3FD-316	115 / 230	8.0	300
Single Voltage	838-3FS-412	115	6.3	1000
	838-3FS-416	115	8.0	800
	838-3FS-420	115	10.0	600
	838-3FS-424	115	12.0	500
	838-3FS-312	115	6.3	400
	838-3FS-316	115	8.3	300

3.1.2 External power supply

There is also an option to use external AC power from 8 to 12 volts AC supplied from an external power supply such as an AC wall transformer or "wall wart". If you opt to use an external AC power supply instead of the onboard transformer, please follow the following steps:

1. Make sure you use an AC power supply (like a "wall wart" type adapter) in the voltage range from 8 to 12 volts AC. Note: the wall wart **MUST** be AC, the more commonly found DC wall warts will **NOT** work.
2. Make sure you do **NOT** strap both the "115" and "230" voltage selection straps.
3. Use two lengths of 22 or 24 gauge wire to connect the following:
 - a. Transformer pad pin 8 to left most "115" strap option **RIGHT** pad. Follow the dashed line labeled "Wall Wart" on the silkscreen.
 - b. Transformer pad pin 7 to transformer pad pin 1. Follow the other dashed line labeled "Wall Wart" on the silkscreen.
4. Connect the two output wires from the AC wall wart to X1 (the AC input connector on the top right of the board).

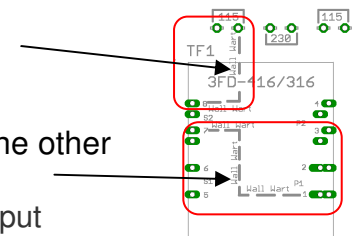

3.2 Parts Assembly

The Renard Plus 32 is a simple device to assemble and test. It is easiest if you build the units by inserting the various components from smallest to tallest.

3.2.1 First Things First

1. Begin by inspecting the PCBs to look for any defects such as cracks or breaks. The holes on the board should be open on both sides. Then inspect and sort out the various parts for the board.

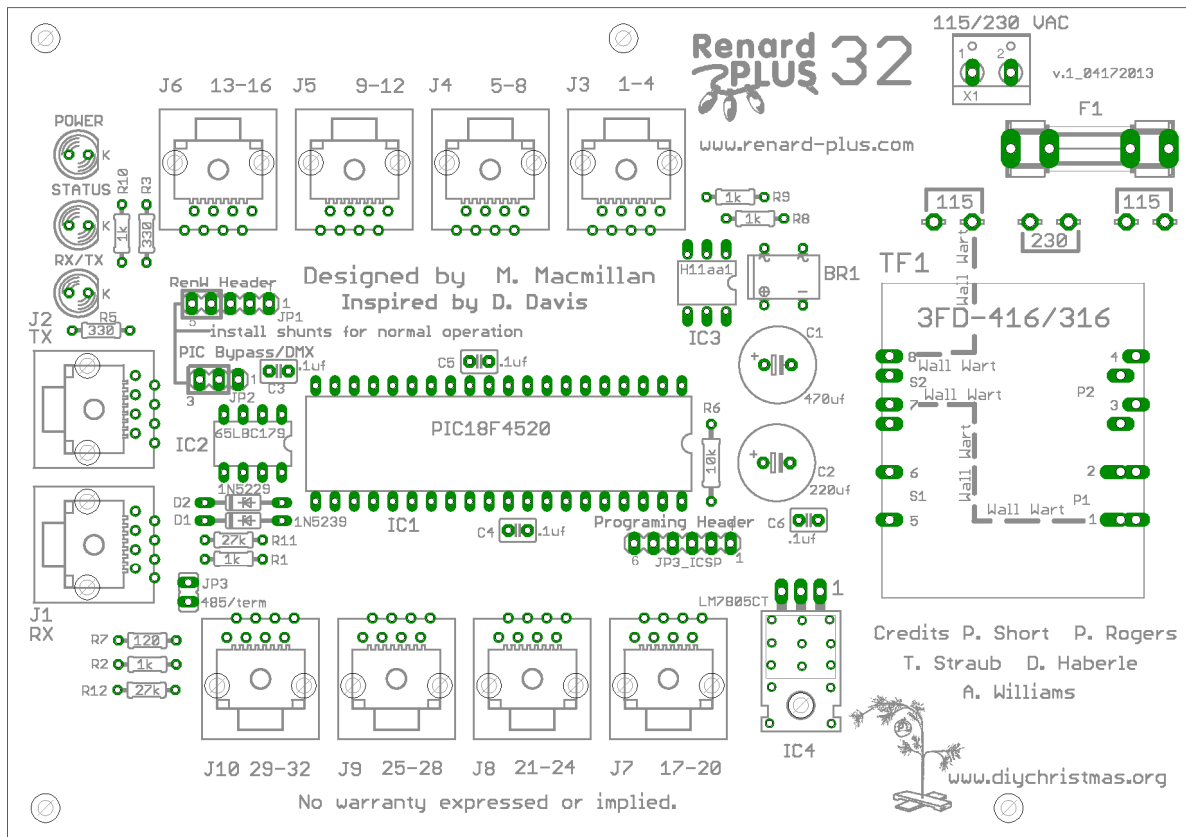

2. Next inspect and sort out the various parts for the board. Make sure you understand which parts are which, and things like resistor codes and component orientation. A separate document on these concepts is available at:

[www.renard-plus.com/files/Tools and Parts ID Guide.pdf](http://www.renard-plus.com/files/Tools%20and%20Parts%20ID%20Guide.pdf)

and on other resource sites like Wikipedia.

3. Follow the assembly guide as follows in the next section.

3.3 Renard Plus 32 Assembly Guide

3.3.1 Set Voltage Option

The boards have the option of running from either 115VAC main, or 220VAC with the recommended on board transformer option. Jumper straps set the desired main AC voltage into the board at X1. It is important to only strap EITHER the two 115 options or the one 220 option. Note the 115 options are strapped individually, and should not be connected to each other.

Step	Instructions	Renard Plus 32
1a <input type="checkbox"/> 110V Option	<p>If the controller will be used for 115 volt AC configuration use 2 leftover clipped leads and form them to individually jumper each of the two 115 pad sets near the transformer. Solder.</p> <p><i>Note: Each set of the two 115 options have individual jumpers and do NOT connect to each other.</i></p> <p>DO NOT JUMPER both 230 and 110 voltage pads at the same time!!</p>	
1b <input type="checkbox"/> 220v Option	<p>If the controller will be used for 220/230 volt AC configuration use 1 leftover clipped lead and form them to jumper the 230 pad near the transformer. Solder.</p> <p>DO NOT JUMPER both 230 and 110 voltage pads at the same time!!</p>	

If you will NOT be using the on board transformer option, but wish to supply 8 to 12 volt AC from an external supply, such as a wall transformer or “wall wart”, please leave these straps off, and refer to the Transformers sections for details on using external AC.

3.3.2 Install the resistors

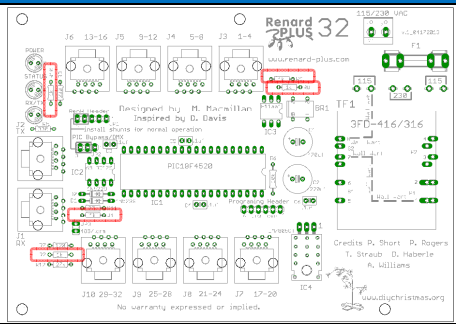
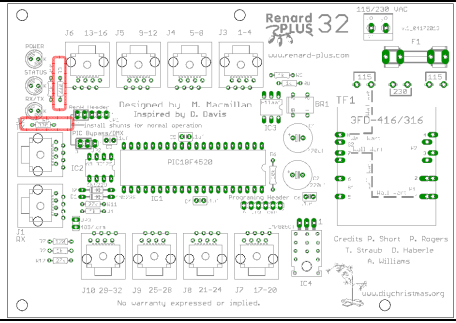
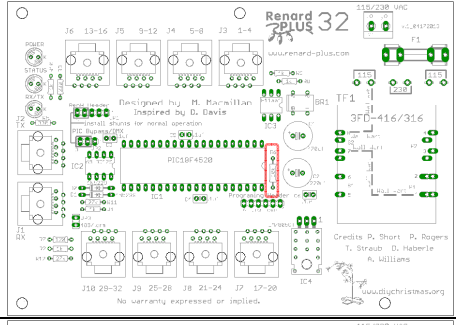
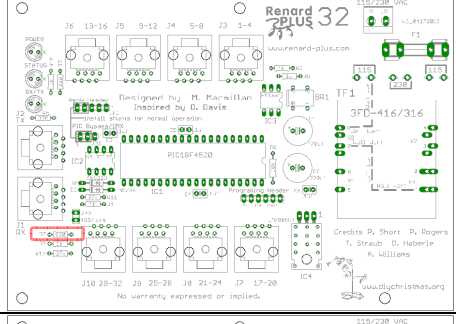
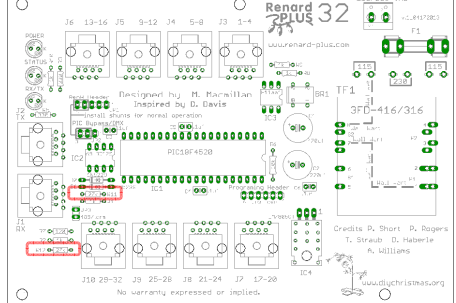
Step	Instructions	Renard Plus 32
2 <input type="checkbox"/>	Install the 1K (brown-black-red) ohm resistors at locations R1, R2, R8, R9, R10. Solder and clip the leads.	
3 <input type="checkbox"/>	Install 330 (orange-orange-brown) ohm resistors at locations R3, R5. Solder and clip the leads.	
4 <input type="checkbox"/>	Install the 10K (brown-black-orange) ohm resistor at location R6. Solder and clip the leads.	
5 <input type="checkbox"/>	Install the 120 (brown-red-brown) ohm resistor at location R7. Solder and clip the leads.	
6 <input type="checkbox"/>	Install 27K (red-violet-orange) ohm resistors at locations R11, R12. Solder and clip the leads.	

3.3.3 Install the diodes

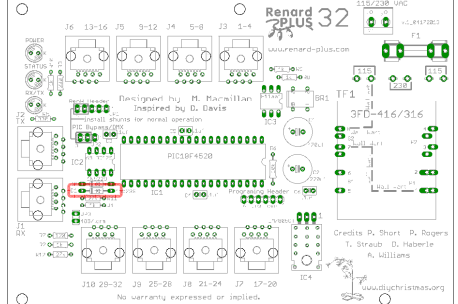
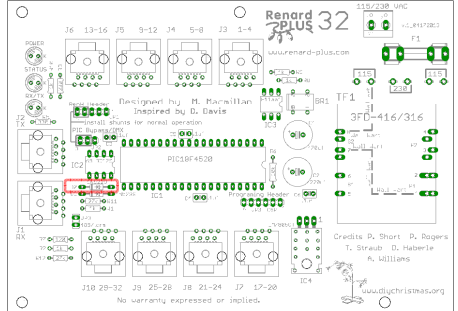
Step	Instructions	Renard Plus 32
7 <input type="checkbox"/>	Install the 1N5239 diode at location D1. The diode is polarized and it can only be used one way. The end with the band (cathode) goes towards the LEFT side of the board with your board oriented as shown. Solder and clip the leads. <div style="text-align: center; margin-top: 10px;">  </div>	
8 <input type="checkbox"/>	Install the 1N5229 diode at location D2. The diode is polarized and it can only go one way. The end with the band (cathode) goes towards the LEFT side of the board. Solder and clip the leads.	

3.3.4 Install IC sockets and Bridge Rectifier

Even though these parts are optional we strongly recommend that sockets be used on all of the IC's. Pin 1 of the IC aligns to the square solder pad on the PCB.

Pin 1 of the IC socket is on the end, closest to the notch.

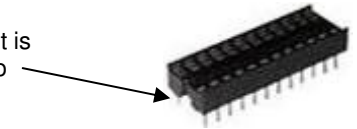

Step	Instructions	Renard Plus 32
9 <input type="checkbox"/>	Install the 6 pin socket at location IC3. Make sure the notched or dimpled end is lined up with the notched end of the silk screen board outline. The notch on the socket should face the right side of the board. Solder one pin and make sure the socket is firmly seated before continuing to solder the remaining pins. Solder all pins.	
10 <input type="checkbox"/>	Install the 8 pin socket at location IC2. Make sure the notched or dimpled end is lined up with the notched end of the silk screen board outline. The notch on the socket should face the right side of the board. Solder one pin and make sure the socket is firmly seated before continuing to solder the remaining pins. Solder all pins.	
11 <input type="checkbox"/>	Install the 40 pin socket at location IC1. Make sure the notched or dimpled end is lined up with the notched end of the silk screen board outline. The notch on the socket should face the right side of the board. Solder one pin and make sure the socket is firmly seated before continuing to solder the remaining pins. Solder all pins.	
12 <input type="checkbox"/>	Install the bridge rectifier at location BR1. The bridge rectifier is polarized and it can only be installed one way. The side with the “+” and the “-” goes towards the bottom of the board and the side with the other 2 “-” go towards the top side of the board. Solder one pin and make sure the part is firmly seated before continuing to solder the remaining pins. Solder all pins.	

3.3.5 Install the capacitors

Step	Instructions	Renard Plus 32
13 <input type="checkbox"/>	Install the 0.1uf Ceramic Capacitors (marked 104) at locations C3, C4, C5, and C6. Solder and clip the leads.	
14 <input type="checkbox"/>	Install the 470uf electrolytic capacitor at location C1. Solder and clip leads. <i>Note: Be sure that the (+) lead is installed in the hole marked with a "+" symbol. The (+) lead is usually longer than the (-) lead, and the (-) lead is identified by a black or white stripe on the capacitor.</i>	
15 <input type="checkbox"/>	Install the 220uf Electrolytic Capacitor at locations C2 which is polarized. Solder and clip the leads. <i>Note: This part has a specific orientation just like C1.</i>	

3.3.6 Install the light emitting diodes

LED's (light emitting diodes) must be installed according to the silk screen pattern on the board. In looking at an LED you will notice a flat spot on one side of the LED:

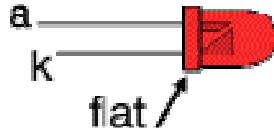

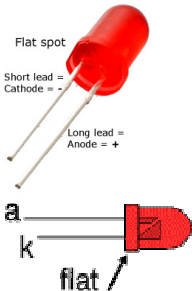
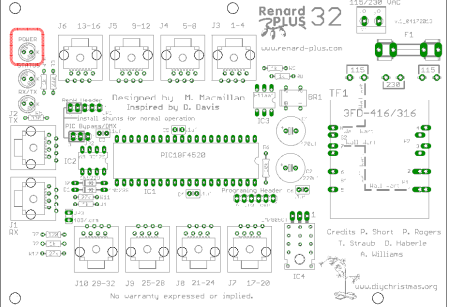
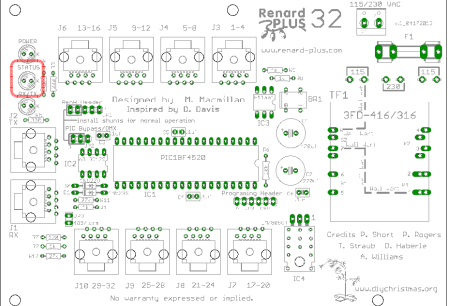
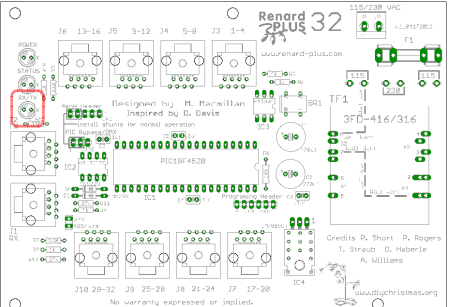

Step	Instructions	Renard Plus 32
16 <input type="checkbox"/>	<p>Install the Red LED at the location marked Power. The LED is polarized. There is a flat side (cathode) that has a short lead and it faces towards the right side of the board. Solder and clip the leads.</p> 	
17 <input type="checkbox"/>	<p>Install the Yellow LED at the location marked Status. The LED is polarized. There is a flat side (cathode) that has a short lead and it faces towards the right side of the board. Solder and clip the leads.</p>	
18 <input type="checkbox"/>	<p>Install the Green LED at the location marked RX/TX. The LED is polarized. There is a flat side (cathode) that has a short lead and it faces towards the right side of the board. Solder and clip the leads.</p>	

3.3.7 Install Misc. Parts

This section covers installation of the miscellaneous parts to complete the board including the headers.

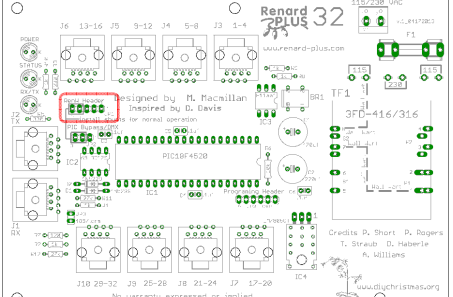
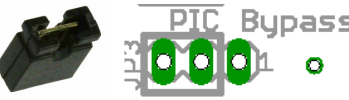
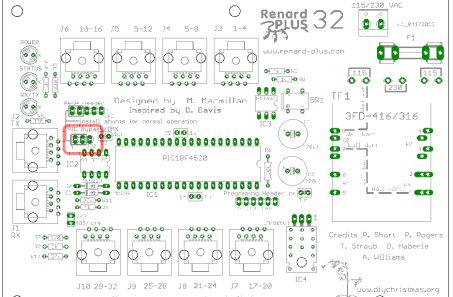
If you purchased or received a single 16 pin or larger header (most cost effective), you will need to cut it into appropriate lengths according to the board specifications. There are one each 6 pin, 5 pin, 3 pin and 2 pin headers required for this board. When installing headers the short side of the header is installed into the board leaving the long side available for headers or jumpers to be connected.

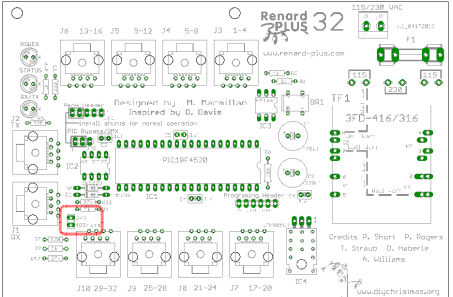
Step	Instructions	Renard Plus 32
19 <input type="checkbox"/>	<p>Install the 5 pin header at location JP1 (RENW header). Solder.</p> <p>Install a shunt jumper on the two left most pins of the header as indicated on the silkscreen.</p> 	
20 <input type="checkbox"/>	<p>Install the 3 pin header at location JP2 (PIC bypass). Solder.</p> <p>Install a shunt jumper on the two left most pins of the header as indicated on the silkscreen.</p> 	
21 <input type="checkbox"/>	<p>Install the 2 pin header at location JP3 (485/term). Solder.</p> <p>Install a shunt jumper on the two pins of the header to enable Terminate of the RS485 communications on the last board in a daisy-chained set of boards. Leave un-jumpered for RS232.</p> 	

Step	Instructions	Renard Plus 32
22 <input type="checkbox"/>	Install the 6 pin header at location JP3_ICSP (PIC programming header). Solder.	
23 <input type="checkbox"/>	Install the 5v linear regulator at location IC4 forming the leads as indicated below. Fold the pins over the shaft of a small screwdriver to create smooth bends. Apply an even layer of heat sync compound on the back of the regulator, then after inserting the leads into the proper holes, secure the IC with a 4-40 bolt, #4 lock washer, and a 4-40 nut. Solder and clip leads. 	
24 <input type="checkbox"/>	Install the RJ45 jacks at locations J1-10. Gently align the eight wires with the matching holes and snap the connector to the board. Solder.	
25 <input type="checkbox"/>	Install the 2 fuse clips at location F1. Solder. Install Fuse at F1. Fuses do NOT get soldered. <i>Note: A fuse can be used to align the fuse clips for soldering as long as you do not overheat it.</i> 	

Step	Instructions	Renard Plus 32
26 <input type="checkbox"/>	Install the terminal block at locations X1. Note: The terminal blocks must be oriented facing outward.	
27 <input type="checkbox"/>	Install the Transformer at location TR1 Note: Line up pins 1/1, 2/2, 3/3, and 4/4 according to the silkscreen layout. Be careful as the transformer can be installed backwards.	

3.3.8 Initial Testing / Final Assembly

At this point you have completed the assembly of the board and you should gently clean the board of any residue and inspect for solder bridges or cold solder joints. What you are looking for are any solder bridges especially around the IC's and other closely spaced parts, or pins that are not fully and cleanly soldered.

If you have any of the IC's (IC1, IC2, IC3) installed – **remove them now**.

Connect a line cord (either 115v or 230v) to the X1 terminal (115/230 VAC).



When you plug in the controller verify the power LED lights up. Verify you have 5v between pins 11 and 12 on the PIC socket as well as between pins 1 and 4 on the 485 chip socket.

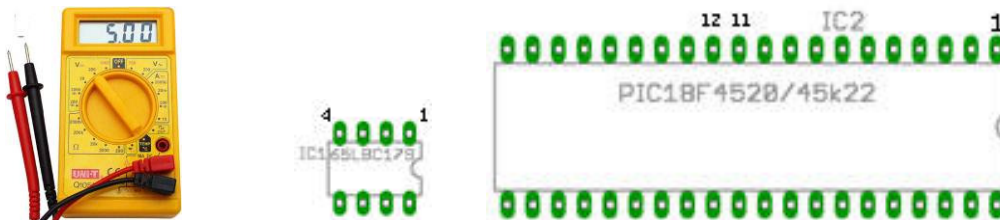

If the voltage does NOT measure +5, remove power and start troubleshooting. Look for solder bridges around the bridge rectifier, or regulator. Double check the regulator number to make sure it is what you expect (something like LM7805 or LM340T-5). Verify the transformer is installed in the correct orientation. Check the Voltage Selection straps for the correct selection. Look for cold solder joints – retouching all solder connections, especially in the power supply area, will often help solve issues like this.

When power measures good, turn off your power supply and continue assembling.

3.3.9 Install the ICs:

Step	Instructions	Renard Plus 32
28 <input type="checkbox"/>	<p>Install the PIC18F4520 in the 40 pin socket at location IC1. The IC is polarized. Gently install the IC so that the notch faces towards the right matching the socket and the silkscreen.</p> <p>Note: Make sure power is OFF before installing ICs!!!</p>	
29 <input type="checkbox"/>	<p>Install the SN65LBC179P in the 8 pin socket at location IC2. The IC is polarized. Gently install the IC so that the notch faces towards the right matching the socket and the silkscreen.</p>	
30 <input type="checkbox"/>	<p>Install the H11AA1 in the 6 pin socket at location IC3. The IC is polarized. Gently install the IC so that the notch faces towards the right matching the socket and the silkscreen.</p>	

3.3.10 Picture of completed board

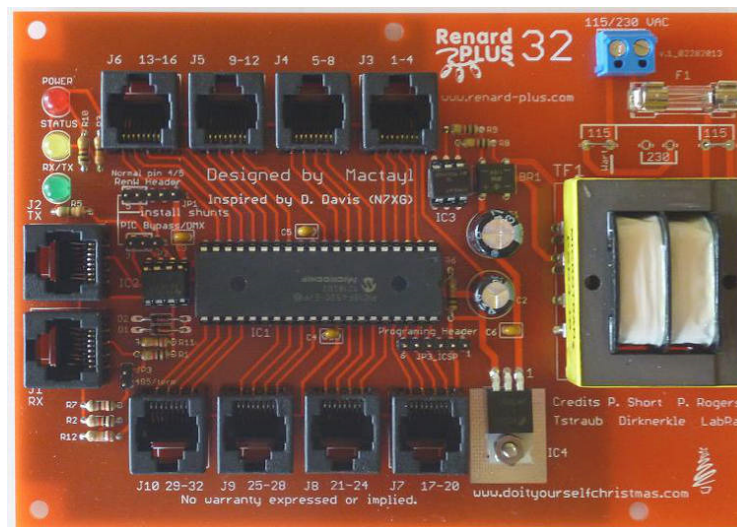

4. Final Steps

At this point you will have now completed the installation of all of the parts to the controller. Again, it is a good idea to gently clean off any final soldering residue and then visually inspect the board and check to make sure there are no solder bridges between the solder pads, and that the solder joints are all a good quality.

4.1 Programming the PIC

Note: The Renard Plus controllers do not use the original Renard firmware used on other Renard devices. Make sure you use the Renard Plus version of the code from the Renard-Plus.com website!

Programming the PIC can be done with the PIC chip plugged into a PIC programmer such as the PICStart from MicroChip or onboard using a programmer like a PicketIII or PicKit2. Programming PIC's using standard assembly is written up in the PIC Programming Manual available on www.renard-plus.com.

4.2 Jumper Settings / Headers

4.2.1 JP1 XBee Header

This header can be used to connect a XBee Wireless module directly to the Renard Plus 32 using a Xbee Snap-in board or indirectly using 3 or 4 wires to a board such as the REN-W. If you are not using XBee Wireless then you must jumper pins 4/5 using a shunt jumper. The following are the pinouts for the Xbee header:

Pin Layout

- 1 = +5VDC
- 2 = N/C
- 3 = GND
- 4 = RX from 485 chip
- 5 = RX in to PIC

Option - Xbee using Snapin Board

Note: When assembling the DIGWDF Xbee SnapIn board (<http://diychristmas.org/store/>) install the female 5 pin header block on the bottom side of the board. Once assembled the SnapIn board can only be plugged in one direction.

4.2.2 JP2 PIC Bypass / DMX

If you are using Start Address Programming, you can use the PIC bypass to allow the data to flow thru the Renard Plus 32 without the usual Renard "address eating". If you use a jumper across pins 1/2 then the data stream that comes into the device goes out exactly as it came in with no addresses consumed by the Renard Plus 32. The default position is a jumper across pins 2/3.

Pin Layout

- 1 = Data In From RS485 IC
- 2 = Data Out to RS485 IC
- 3 = Data Out from PIC

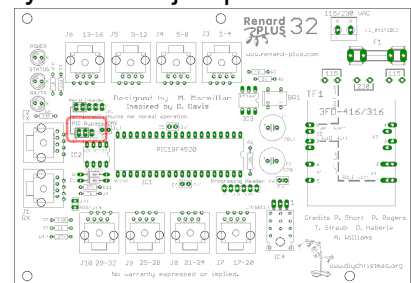
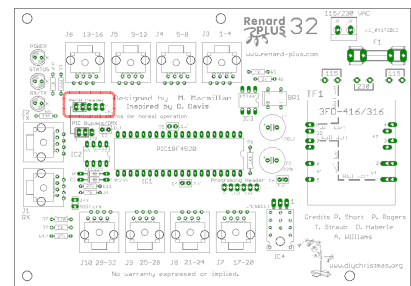

4.2.3 JP3 RS485 Terminator

There are situations where the communications from the computer might require termination. Usually line reflections or other environmental conditions might disrupt communications to the controller. You might see missed light transitions, jumpy animation, or complete no operation. In this case, adding termination *may* return reliable communications assuming everything else is working right.

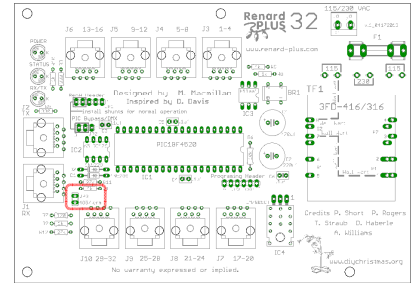

4.2.4 Programming (ICSP Header)

This header allows the PIC to be programmed while the PIC is installed on the board. The following are the pin-outs for this header:

Pin Layout

- Pin 1 = MCLR
- Pin 2 = +5 volts
- Pin 3 = GND
- Pin 4 = PGD
- Pin 5 = PGC
- Pin 6 = PGM/RB5

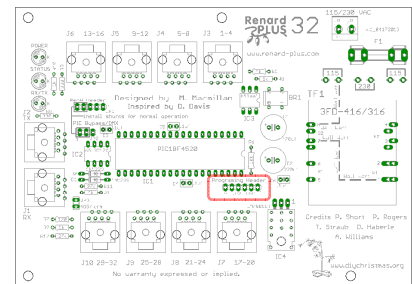

4.3 Connecting the Renard to your PC

This board contains 2 RJ45 connectors that are used to receive data and pass data to the next controller.

J2 TX	RS485 outgoing data to next controller
J1 RX	RS485 incoming data from either a RS485 converter or another controller

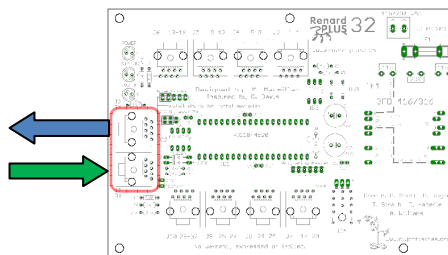

The data wiring of the Renard Plus T32 is the same as other Renard boards including the Renard SS series so you can follow the same cabling requirements between other Renards and Renard Plus boards as follows:

For RS232, RP32 J1 RX pin 4 connects to the serial TX pin (pin 3 of a DE9 female) and J1 pins 5 and 2 and/or 1 connect to serial GND (pin 5 of a DE9 female). For RS485 operation, J1 pins 1 and 2 are GND, pin 4 is Data-, and pin 5 is Data+ on the RS485. RS485 connections vary.

There are many options to connect your computer to the Renard Plus 32. Pictured here is a Hexim HXSP-2018F USB to RS485 adapter. When selecting an adapter look for ones that have an easy to use screw terminal like this one.



4.3.1 RJ45 Wiring

A standard CAT5 (or better) RJ45 networking cable can be used to connect the Renard to:

1. Your PC RS485 adapter
2. Another Renard for daisy chain operation or
3. SSRs if your board requires the use of SSRs (RP32 does not).

The cable must be a straight thru style and NOT a cross-over type cable. Just check and make sure that the pins on one end of the cable connect to the same pin on the other end of the cable (the wire colors in the connector are a way to tell- look for the same color pattern on both connectors).

This is an example of a data cable wired to the EIA-568B standard. There are eight pins, numbered from left to right, looking at the jack.

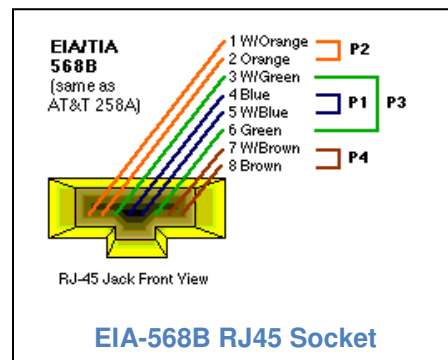

4.3.2 Computer Setup

If you are using the Vixen sequencing software to drive your Renard Plus, it will require either one of the following plugins:

- Renard Dimmer [Vixen 1.1.*]
- Renard Dimmer (modified) [Vixen 2.*]

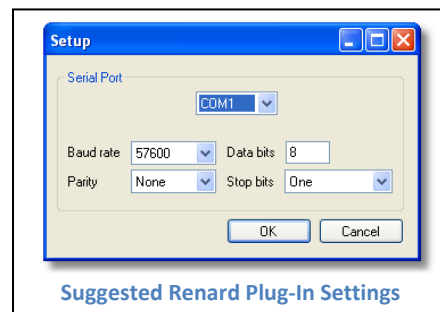

If you are using an Xbee, the baud rate must be 57600.



4.4 Final Testing

The Renard Plus 32 has 3 diagnostic LED status lights:

4.4.1 Diagnostic LED Status Lights

 PWR	Power - Will be on when power is applied
 FE	Status – Will blink every few seconds to indicate the microprocessor is active
 RX/TX	RX/TX – Active when sequence is running

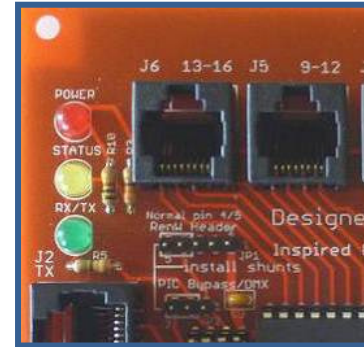

For normal operation you should have the power LED lighted and the status “FE” LED blinking every few seconds (the PIC must be programmed). If you are running a sequence you will also see the RX LED flashing as well.

You can connect the Renard Plus 32 to your PC using a standard CAT5 network cable from the Renard to a RS485 connection on your PC. Connect the RP32 to SSRs using the same type of cable.

The data wiring of the Renard Plus 32 is the same as other Renard boards such as the RenardSS and others. Standard CAT5 network cables with RJ45 out connector can be used to inter-connect directly with other controllers.

Program a Vixen sequence to turn on/off each of the channels on the controller. We would suggest that each channel is turned on for 4 or 5 seconds.

Congratulations, with the completion of a successful test, you have assembled your Renard Plus 32 – now the fun part starts, sequencing to use your new channels!

5. Parts Placement Diagram

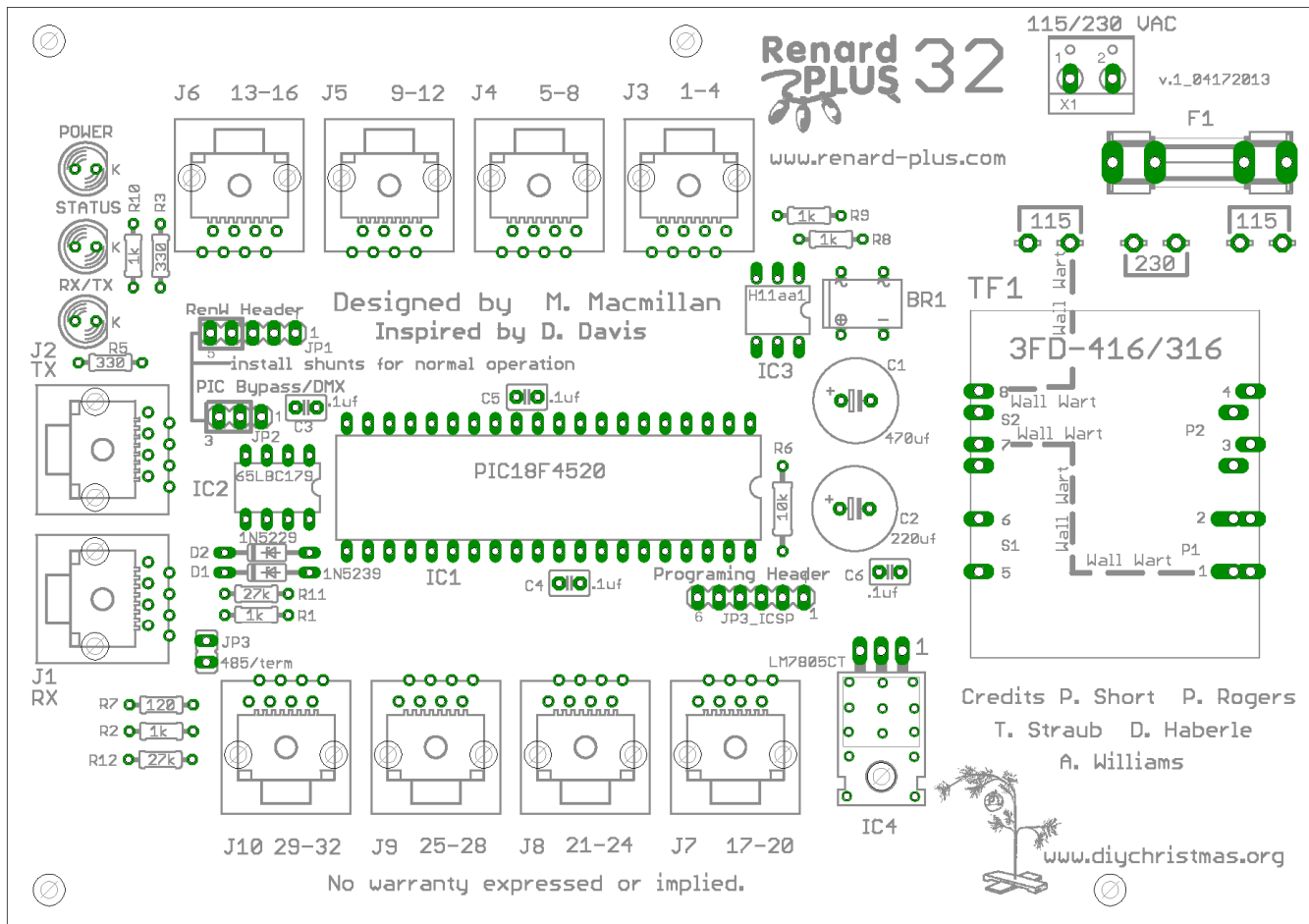

6. Notes

Use the following page(s) for notes about the board.